

# Operating Manual RVM Rotary Valve

Advanced Microfluidics SA

Original instructions - March 2025

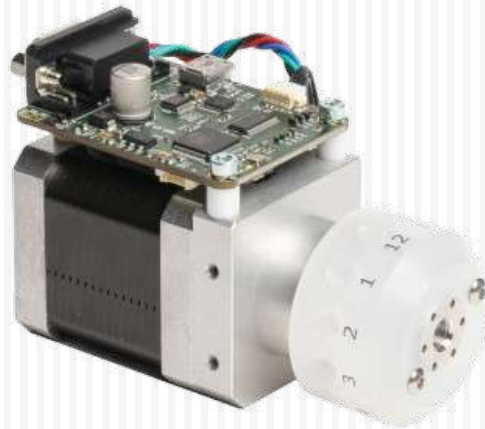

Copyright © 2016

Published by:  
ADVANCED MICROFLUIDICS SA  
Chemin de la Dent d'Oche 1A  
1024 Ecublens  
Switzerland

<https://amf.ch/>

*Version 2.2, en*





The information and data contained in this documentation is subject to change without notice. The reproduction, distribution and utilization of this document as well as the communication of its contents to others without explicit authorization is prohibited.

All rights reserved in the event of the grant of a patent, utility model or design.

The general terms and conditions of *Advanced Microfluidics SA* apply. Alternative agreements must be in written form.

*Advanced Microfluidics SA* shall not be liable for errors contained in this document or for incidental or consequential damages in connection with the furnishing, performance, or use of this material.



# Contents



<b>1</b>	<b>Introduction</b> .....	<b>6</b>
1.1	Foreword	6
1.2	Application Purpose	6
1.3	Functional Description	6
1.3.1	Motor models .....	6
1.3.2	Valve models .....	7

<b>1</b>	<b>Hardware</b>	
<b>2</b>	<b>Hardware description</b> .....	<b>9</b>
2.1	Glossary	9
2.2	RVM motor models	9
2.3	Cabling	10
2.3.1	Power supply .....	10
2.3.2	Data communication .....	10
2.4	Chemical compatibility	12
<b>3</b>	<b>Valve module description</b> .....	<b>14</b>
3.1	Distribution series	14
3.1.1	Description .....	14
3.1.2	Port numbering .....	15
3.2	On/off series	16
3.2.1	Port numbering .....	16
3.3	Switch series	17
3.3.1	Port numbering .....	17
<b>4</b>	<b>Maintenance operations</b> .....	<b>19</b>
4.1	Cleaning procedure	19

<b>4.2</b>	<b>Gas bubbles</b>	<b>20</b>
4.2.1	Bubble sources	20
4.2.2	How to avoid/reduce the creation of nuclei	21
4.2.3	Remove the trapped bubbles	22

## II

## Software

<b>5</b>	<b>Software Communication</b>	<b>24</b>
<b>5.1</b>	<b>Communication Protocol</b>	<b>24</b>
5.1.1	Data Terminal Protocol	24
5.1.2	Using DT Protocol with Microsoft Windows	25
5.1.3	RVM Command Set	26
5.1.4	Troubleshooting	32
<b>6</b>	<b>Coding examples</b>	<b>33</b>
<b>6.1</b>	<b>Labview VI</b>	<b>33</b>
6.1.1	Description	33
6.1.2	Requirements	34
<b>6.2</b>	<b>Python scripting</b>	<b>34</b>
6.2.1	Description	34
6.2.2	Requirements	35

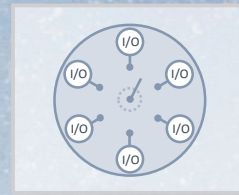

# 1. Introduction



## 1.1 Foreword

*Advanced Microfluidics SA's* team thanks you for acquiring a RVM rotary valve. This operating manual is dedicated to help you make the most of this device and thus bring success to your microfluidic projects. We remain available for any questions or suggestions that you may have.

The RVM rotary valve system may only be operated after carefully reading and understanding this manual.

## 1.2 Application Purpose

The RVM rotary valve is a precision liquid handling system designed to control your fluidic paths. It is controlled by an external computer or microprocessor and is powered either by USB or by an 18-24V power supply, depending on the model.

## 1.3 Functional Description

### 1.3.1 Motor models



FIGURE 1.1 – Low power model - RVMLP



FIGURE 1.2 – Fast model - RVMFS

### 1.3.2 Valve models

Different valve models exist, as explained further, but here are some main details regarding all models.

The valve is made of fluoropolymers which have an outstanding chemical resistance. The plug which selects the connected channel is made of PTFE or UHMW-PE and the outer part, called valve seat, where the user can connect standard microfluidic fittings, is made of PCTFE.

The valve module, which is a closed loop system, works as follows:

- The user sends a command to connect a specific port
- The plug is rotated by a stepper motor through the plug drive
- A position sensor detects very precisely the position of the plug thanks to a number of indexes integrated in the plug itself
- Using this feedback the stepper motor can be stopped when the plug has reached the desired position

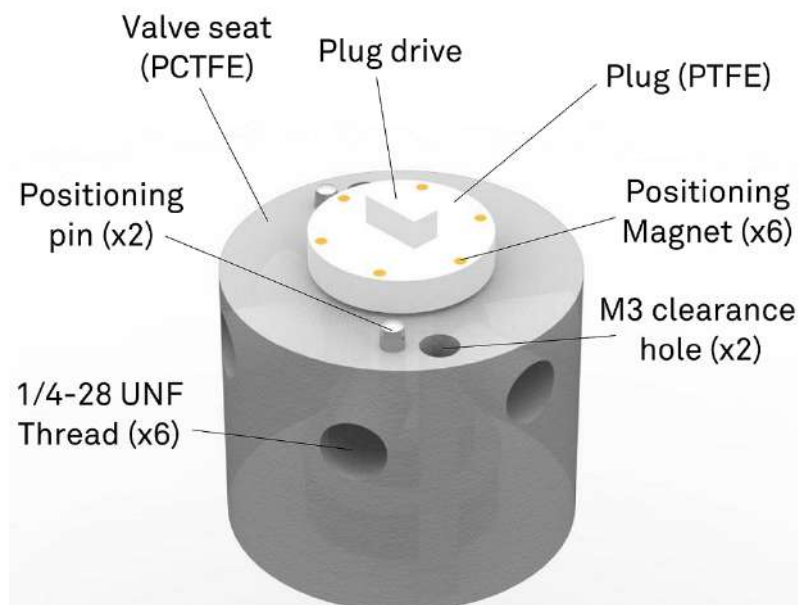

FIGURE 1.3 – Nomenclature for the valve module

The valve module is removable by unscrewing the two M3x30 screws. The entire procedure is described in the maintenance section. The rated pressure for the valve module is 5 bars (0.5 MPa or 72.5 PSI).



# Hardware

<b>2</b>	<b>Hardware description</b> .....	<b>9</b>
2.1	Glossary	
2.2	RVM motor models	
2.3	Cabling	
2.4	Chemical compatibility	
<b>3</b>	<b>Valve module description</b> .....	<b>14</b>
3.1	Distribution series	
3.2	On/off series	
3.3	Switch series	
<b>4</b>	<b>Maintenance operations</b> .....	<b>19</b>
4.1	Cleaning procedure	
4.2	Gas bubbles	



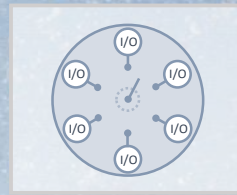
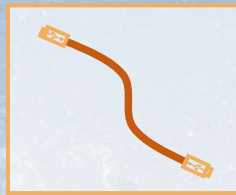

## 2. Hardware description



### 2.1 Glossary

**Carryover:** Contamination of a volume of fluid by residual fluid from a previous pick up or dispense. Carryover causes variability in the final volume and concentration.

**Carryover volume:** Volume of liquid that will be mixed with the next liquid. It is not stuck, but will be swept next time a liquid passes.

**Cavitation:** Formation of vapor cavities in a liquid – i.e. small liquid-free zones ("bubbles" or "voids") – that are the consequence of forces acting upon the liquid. It usually occurs when a liquid is subjected to rapid changes of pressure that cause the formation of cavities where the pressure is relatively low.

**Dead volume:** Volume that is “stuck” in the system (dead end), which is not cleanly swept and relies on diffusion to clear out.

**Internal volume:** Volume inside the system, from entrance to exit.

**Port:** The connection or orifice through which sample may be injected or dispensed.

**Priming:** Completely filling the pump tubing and syringe with bubble-free fluid to allow sustained, reproducible pumping action.

**Void volume:** Sum of the carryover volume and dead volume.

**Wetted surfaces:** The surfaces which are contacted by the sample stream.

### 2.2 RVM motor models

The main differences between the RVMLP and RVMFS can be found hereafter:

Abbr.	Configuration	Power	Rotation time for 180°	Weight (total module)	Dimensions
RVMLP	Low power motor	5-10 VDC, 0.5 A peak	1.5 s	250 g	29 x 38.3 x 111.8 mm
RVMFS	Fast motor	18-24 VDC, 2 A peak	400 ms	450 g	42.3 x 60 x 95.9 mm

TABLE 2.1 – RVM motor models

## 2.3 Cabling

### 2.3.1 Power supply

Depending on the model that you have chosen, the power source is different.

#### Low power - RVMLP & Fast model - RVMFS

The low power model uses a single mini-USB cable for both the power and the communication. The female mini-USB connection works as a virtual serial port. The connection can be done by any mini-USB/USB cable provided that the provided ferrite of type 74271111S is locked around the cable. The fast model uses a mini-USB cable for the communication only.



FIGURE 2.1 – Generic mini-USB cable



FIGURE 2.2 – Ferrite 74271111S from Würth Elektronik to be locked around the USB cable connected to the RVM

#### Fast model - RVMFS

The fast rotary valve requires an additional AC/DC adaptor. The mini-USB cable is still required for data communication.

It is possible to use a custom cable that only plugs in the the DB9 connector for communication and power. Please contact us with your connection requirements if you'd like us to do this cable for you.

### 2.3.2 Data communication

#### Low power - RVMLP & Fast model - RVMFS

Data communication is possible for both modules with USB communication.

#### Fast model - RVMFS

The fast model can also be controlled using the DB9 connector<sup>1</sup>.

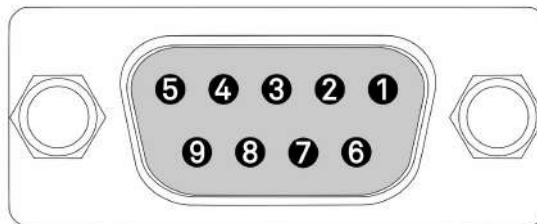

FIGURE 2.3 – DB9 pin-out on device side (RVMFS)

By default, the RS-232 protocol is installed on the RVM-FS. The protocols for RS-485 and RS-422 require an additional chip (connections are planned on the PCB) and a small firmware development. The CAN protocol also requires an additional chip (connection are planned on the PCB), but needs a more extensive firmware update and testing.

<sup>1</sup>Proper designation is DE-9 but the DB9 appellation is the most commonly used.

In combination to all protocols, it is possible to have auxiliary connections, such as a power supply directly connected on the DB9 or a DCD (Data Carrier Detect) which can be adapted to your needs.

Pin	Abbreviation	Name	Typical Purpose
1			
2	TX	Transmitted Data	Carries data from DCE (RVM) to DTE
3	RX	Received Data	Carries data from DCE to DTE
4			
5	GND	Ground	Zero voltage reference
6			
7	CTS	Clear To Send	Not implemented
8	RTS	Request To Send	Not implemented
9			

TABLE 2.2 – Pin assignment of the DB9 connector female on the RVMFS for RS232 protocol

Pin	Abbreviation	Name	Typical Purpose
1			
2	D-	Data	Negative driver
3			
4			
5	GND	Ground	Zero voltage reference
6			
7			
8	D+	Data	Positive driver
9			

TABLE 2.3 – Pin assignment of the DB9 connector female on the RVMFS for RS485 protocol

Pin	Abbreviation	Name	Typical Purpose
1			
2	TX-	Transmitted Data	Carries data from DCE (RVM) to DTE. Negative output
3	RX+	Received Data	Carries data from DCE to DTE. Positive input
4			
5	GND	Ground	Zero voltage reference
6			
7	RX-	Received Data	Carries data from DCE to DTE. Negative input
8	TX+	Transmitted Data	Carries data from DCE (RVM) to DTE. Positive output
9			

TABLE 2.4 – Pin assignment of the DB9 connector female on the RVMFS for RS422 protocol

Pin	Abbreviation	Name	Typical Purpose
1			
2			
3			
4	CANH	CAN-High	CAN-High
5	GND	Ground	Zero voltage reference
6			
7			
8			
9	CANL	CAN-Low	CAN-Low

TABLE 2.5 – Pin assignment of the DB9 connector female on the RVMFS for CAN protocol

Pin	Abbreviation	Name	Typical Purpose
1	DCD	Data Carrier Detect	Not implemented
2			
3			
4			
5	GND	Ground	Zero voltage reference
6	PWR	Power	Power supply input (18-24 VDC)
7			
8			
9			

TABLE 2.6 – Pin assignment of the DB9 connector female on the RVMFS for auxiliary connections

Pin	Abbreviation	Name	Typical Purpose
1			
2	TX	Transmitted Data	Carries data from DCE (RVM) to DTE
3	RX	Received Data	Carries data from DCE to DTE
4			
5	GND	Ground	Zero voltage reference
6	PWR	Power	Power supply input (18-24 VDC)
7			
8			
9			

TABLE 2.7 – Pin assignment of the DB9 connector female on the RVMFS for power+ RS232 connections

The pin assignment is always given from the point of view of the AMF module.

## 2.4 Chemical compatibility

The following parts can be in contact with the liquid:

1. The valve seat: PCTFE
2. The valve plug: PTFE or UHMW-PE

These materials offer an excellent chemical compatibility. However Advanced Microfluidics SA cannot be held responsible for damages caused by the use of a specific chemical. Before using the device with a given chemical, please make sure that it is compatible with the aforementioned materials.



*The valve should not be used to process explosive or highly flammable fluids.*

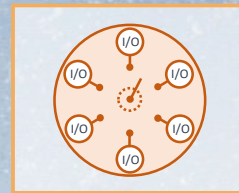

## 3. Valve module description



The RVM is available with 3 valve model families:

- The **distribution series**, where a single port is selected to connect to the top of the valve
- The **on/off series**, a simple switch to determine if the liquid passes or not
- The **switch series**, where the ports are connected to their neighbour, two-by-two

For all valve types, the channels have a standard diameter of 0.5 mm in the valve seat and in the plug (other diameters available). Standard 1/4-28 UNF fittings can be connected to these channels.

You will find the standard models below. For any other request, please contact us directly.

Type	Reference	Nb ports	Internal volume	Carryover volume	Fluid Path Diameter	Wetted Materials
Distribution	V-D-1-6-050-C-P	6	2.5 $\mu\text{L}$	1.5 $\mu\text{L}$	0.5 mm	PCTFE, PTFE
Distribution	V-D-1-8-050-C-P	8	2.5 $\mu\text{L}$	1.5 $\mu\text{L}$	0.5 mm	PCTFE, PTFE
Distribution	V-D-1-8-100-C-U	8	13.7 $\mu\text{L}$	6.7 $\mu\text{L}$	1 mm	PCTFE, UHMW-PE
Distribution	V-D-1-10-050-C-U	10	3.5 $\mu\text{L}$	1.7 $\mu\text{L}$	0.5 mm	PCTFE, UHMW-PE
Distribution	V-D-1-10-100-C-U	10	13.7 $\mu\text{L}$	6.7 $\mu\text{L}$	1 mm	PCTFE, UHMW-PE
Distribution	V-D-1-12-050-C-U	12	3.5 $\mu\text{L}$	1.7 $\mu\text{L}$	0.5 mm	PCTFE, UHMW-PE
On/Off	V-O-1-2-050-C-P	2	3.0 $\mu\text{L}$	-	0.5 mm	PCTFE, PTFE
On/Off	V-O-1-2-075-C-P	2	6.6 $\mu\text{L}$	-	0.75 mm	PCTFE, PTFE
Switch	V-S-1-4-050-C-P	4	2.8 $\mu\text{L}$	0.8 $\mu\text{L}$	0.5 mm	PCTFE, PTFE
Switch	V-S-1-6-050-C-P	6	2.5 $\mu\text{L}$	0.6 $\mu\text{L}$	0.5 mm	PCTFE, PTFE

### 3.1 Distribution series

#### 3.1.1 Description

The distribution valve features N microfluidics ports that can be connected **one at a time** to the top part of the valve, where N is the number of ports of the specific model. The very small channel diameters allow for a minimal carryover volume when changing position.

**Note** — Known aliases for the VD1-6.

7-port/1-channel valve, 6-port selection valve, 7-port/6-position valve

The same aliases can be used for the other distribution models, changing the number of ports

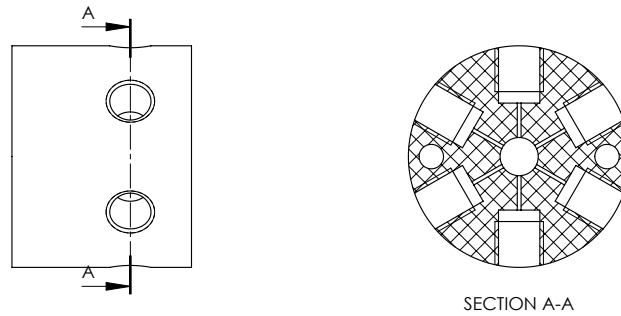

FIGURE 3.1 – [VD1-6] Section view of the PCTFE valve seat revealing the microchannels

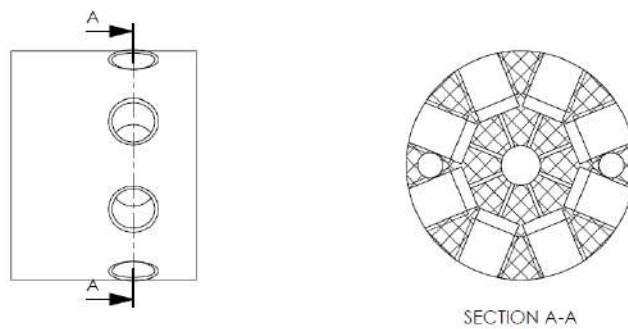

FIGURE 3.2 – [VD1-8] Section view of the PCTFE valve seat revealing the microchannels

### 3.1.2 Port numbering

You will find the port numbers in Figure 3.3 for the VD1-6 model and in Figure 3.4 for the VD1-8 model:

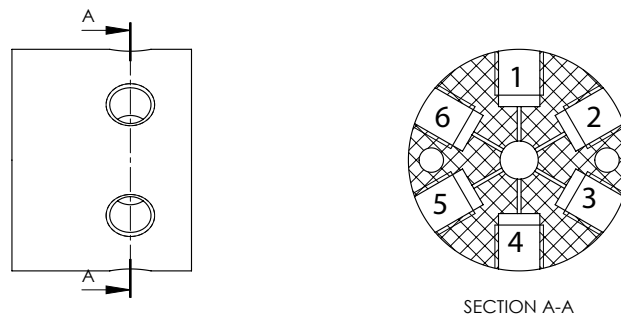

FIGURE 3.3 – [VD1-6] Section view of the PCTFE valve seat with port numbering

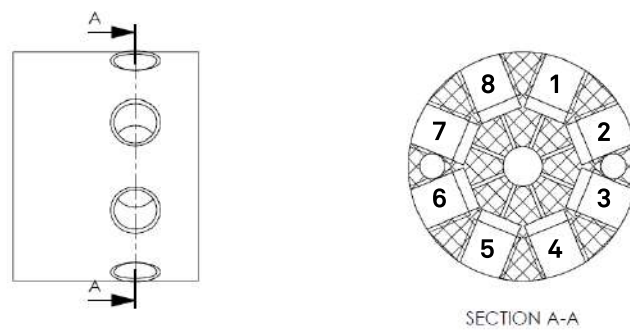

FIGURE 3.4 – [VD1-8] Section view of the PCTFE valve seat with port numbering

**Note — Direction of rotation.**

The command  $I\langle n \rangle$  corresponds to a clockwise rotation of  $60^\circ$  or  $45^\circ$  when incrementing the port number by 1. The command  $O\langle n \rangle$  corresponds to a counterclockwise rotation of  $60^\circ$  or  $45^\circ$  when decrementing the port number by 1.

If you are on port 3, the command  $I\langle 4 \rangle$  will be executed with a  $60^\circ$  or  $45^\circ$  rotation of the plug, while the command  $O\langle 4 \rangle$  will be executed with a  $300^\circ$  or  $315^\circ$  rotation of the plug.

### 3.2 On/off series

The on/off series allows to stop a flow and act as a switch. Currently, a 2-port model is available (Reference VO1-2), where the ports are opposite each other (i.e. separated by  $180^\circ$ ).

**Note — Known aliases.**

Isolation valve, shutoff valve

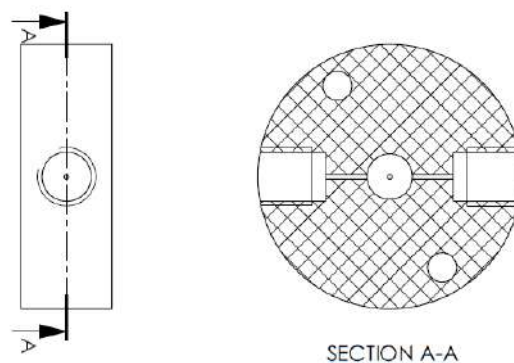

FIGURE 3.5 – [VO1-2] Section view of the PCTFE valve seat revealing the microchannels

#### 3.2.1 Port numbering

You will find the port numbers in Figure 3.6:



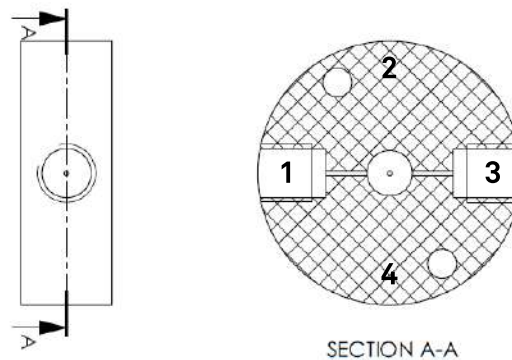

FIGURE 3.6 – [VO1-2] Section view of the PCTFE valve seat with port numbering

**Note — Direction of rotation.**

The command  $I<n>$  corresponds to a clockwise rotation of  $90^\circ$  when incrementing the port number by 1. The command  $O<n>$  corresponds to a counterclockwise rotation of  $270^\circ$  when decrementing the port number by 1.

If you are on port 3, the command  $I<4>$  will be executed with a  $90^\circ$  rotation of the plug, while the command  $O<4>$  will be executed with a  $270^\circ$  rotation of the plug.

### 3.3 Switch series

The switch series allows to connect neighbouring ports two-by-two. Currently, a 6-port model is available (Reference VS1-6), where the ports are separated by  $60^\circ$ .

**Note — Known aliases.**

6-port/2-position valve, 6-port/3-channel valve, loop valve

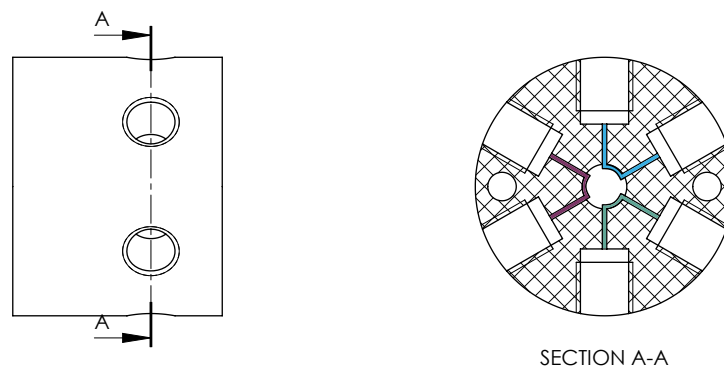

FIGURE 3.7 – [VS1-6] Section view of the PCTFE valve seat revealing the microchannels

#### 3.3.1 Port numbering

You will find the port numbers in Figure 3.8:

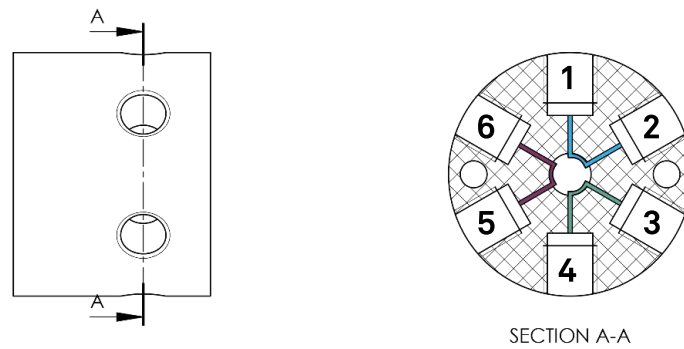
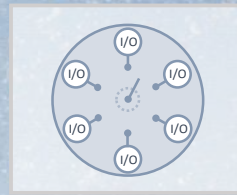

FIGURE 3.8 – [VS1-6] Section view of the PCTFE valve seat with port numbering

**Note — Direction of rotation.**

The command I<n> corresponds to a clockwise rotation of  $60^\circ$  when incrementing the port number by 1. The command O<n> corresponds to a counterclockwise rotation of  $60^\circ$  when decrementing the port number by 1.

If you are on port 3, the command I<4> will be executed with a  $60^\circ$  rotation of the plug, while the command O<4> will be executed with a  $300^\circ$  rotation of the plug.



## 4. Maintenance operations



### 4.1 Cleaning procedure

A cleaning procedure should be performed at the end of each day or in between two different experiments. For an effective cleaning, pass one of the solutions below (depending of your application) at least twice in each tube connected:

- Bleach solution to kill microorganisms : 1% chlorine bleach and deionized water
- Detergent solution to remove debris: 1% detergent (Mucasol for example) and deionized water  
**Note:** 2% RBS 25 can also be used. For blood or plasma manipulation, you may use 1% Alconox. For the valve, you can make this washing step into a ultrasonic bath after a long period of using it.
- Rinsing water to prepare the valve for your next experiment: deionized water  
**Note:** Before the the rinsing step with the deionized water, you can add a washing step with a solvent such IPA or 70% ethanol (same manipulations as for the rinsing step)

Thanks to our small internal volume, each cleaning cycle is extremely efficient. These solutions can be directly added to your system for automatic cleaning between experiments.

**Note — Additional cleaning.** If your experiment creates precipitates, you may need to do a more extensive cleaning cycle, by manually removing the valve head. Please contact us for further details.

## 4.2 Gas bubbles

Gas bubbles in a microfluidics setup is a very common issue and it can be quite difficult to address it. The bubbles can be trapped or directed into a waste output, but there is always a risk of some gas bubbles being created in the setup. The goal of the following section is to give you some hints to avoid them as much as possible and to remove them if they are trapped.

### 4.2.1 Bubble sources

#### Gas coming from leakage

The first possible source of gas bubble comes from the aspiration by the pumping system of external air. This is possible when some part of the microfluidics setup is not air tight. We propose a methodical approach to identify the leakage source. First check the following elements of the microfluidics setup:

- **Connectors:** Verify that every connector is tightly screwed/connected and that it suits well with the tubing you are using. We advise using connectors with a PTFE ferrule that is compressed when the connector is screwed. Make sure that the mating surfaces (PTFE ferrule and valve port surface) are clean and without scraps. To test if the leakage comes from a specific connector, spray a solution containing detergent around the connector and pressurize at 1 or 2 bars the connection with a syringe full of air for example. If there is a leakage, you will see some bubbles around the connector.
- **Valve:** Keep the solution you are passing through the valve as clean as possible. If dust or solid particles pass through your tubing and get stuck in the valve, it can create groove in the valve when this one is rotating. This will eventually lead to leakage and the valve will have to be changed. If you suspect that the valve is leaking, you can plug the port you are not using with a cap to see if it reduces the leakage. If the leakage is reduced, it means that the valve is damaged. After running a lot of cycles, the valve can wear out and the sealing between the rotor and the stator may be defective.

As a general rule, to check if the valve or the syringe is the source of your bubble problem, change them one at a time and check if the situation is better.

#### Gas coming from the solution

The concentration of air molecule is given by the Henry's law:  $c_s = H(T)p_g$  where  $H(T)$  is the solubility constant (increase if the temperature  $T$  decrease) and  $p_g$  is the pressure of the gas in vapor phase. We have an equilibrium when the actual concentration of gas in the liquid  $c$  is equal to  $c_s$ . When the temperature or the pressure changes, there is some variation of  $c_s$  which leads to a non-equilibrium state described by:  $\zeta = c/c_s - 1$ . When  $\zeta < 0$ , we have a undersaturation situation and the gas wants to go in the solution (would reduce the size of the bubbles) and when  $\zeta > 0$ , we have a supersaturation situation and the gas wants to go out of the liquid and this makes bubbles growing. This supersaturated situation occurs when we reduce the pressure (by aspirating the liquid with a pump for example) or when we increase the temperature.

The bubbles created in the solution have a starting point called a nuclei and when this nuclei is formed, the bubbles start growing due to a supersaturated situation. Those nuclei can appear in the bulk of the solution if we have a strong supersaturated solution ( $\zeta \gg 0$ ) and this results in microbubbles flowing continuously through your tubing, or they can appear on the surface of your tubing/connector/valve/syringe due to strong supersaturated solution (nuclei form on the surface and then in the bulk because the surface acts as a nuclei catalyzer) or due to crevices or sharp edges during the wetting as shown in Figure 4.1.

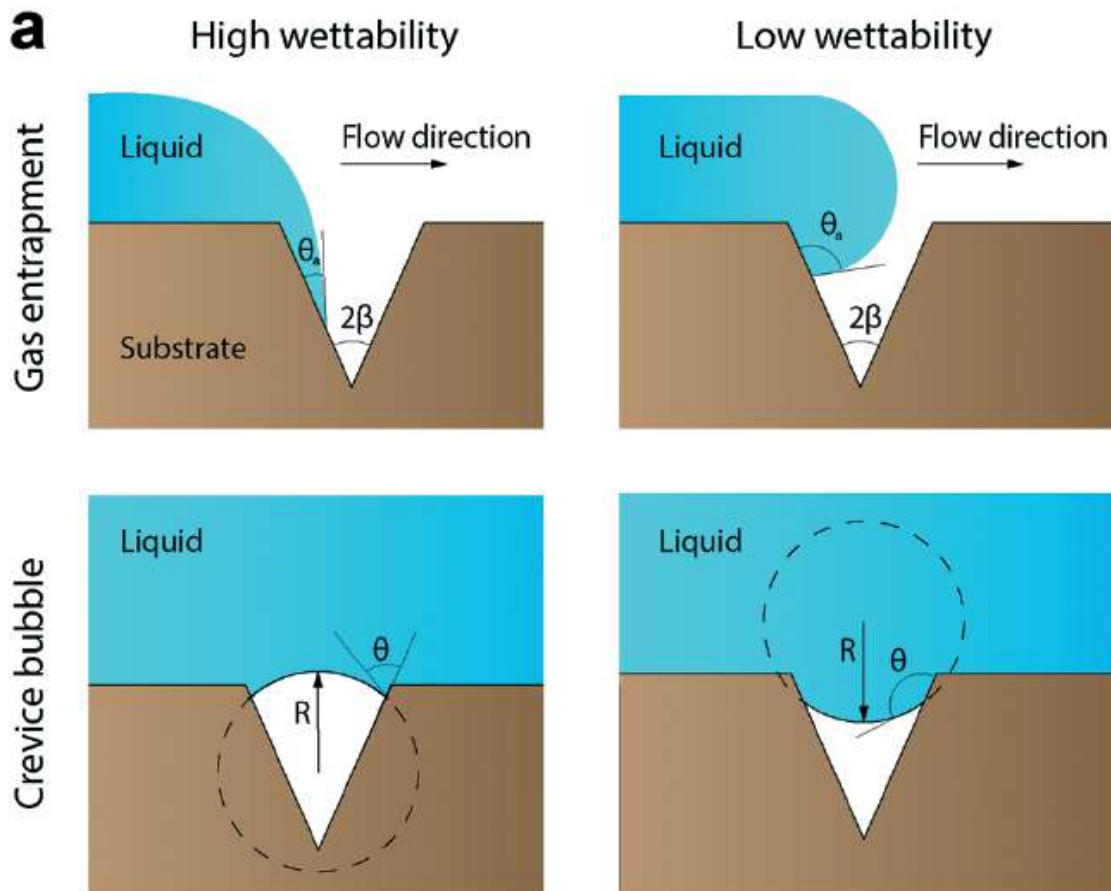

FIGURE 4.1 – Image that describe the formation of bubble due to a crevice during the wetting of the microfluidic network (source : Pereiro, Iago, et al. "Nip the bubble in the bud: a guide to avoid gas nucleation in microfluidics." Lab on a Chip 19.14 (2019): 2296-2314)

The crevice or sharp edge bubbles are the main source of "in solution created" bubbles. It acts as gas tank and when we have a supersaturation situation, the gas volume increases until the bubble is too big to stay trapped by the surface and part of bubble is released. This gas tank is a continuous source of bubble and more you are in a supersaturation situation, more often you will have bubble released from this gas tank. The surface nuclei are maintained on the surface due to the surface tension (the more hydrophobic the surface is, the more the gas bubble will stay trapped) and act as a trap for the microbubbles that are flowing through the tubing. Because of this we have an accumulation effect, the surface bubbles become bigger and bigger until they are too big to be maintained by the surface and they are then released.

#### 4.2.2 How to avoid/reduce the creation of nuclei

- Degas your solutions before using them and in the best case, keep them in this low gas concentration until they are used (for example, keep them under vacuum)
- Avoid large change of pressure and high velocity flow
- Try to keep your lab and your setup under a constant temperature (for example during the night, the temperature may decrease and re-increase in the morning leading to bubble creation)
- **Connectors:** Try to avoid as much as possible sharp edges and dead volume in your connectors and try to avoid change of diameter in your tubing.

- **Valve:** As for the leakage, try to avoid dust and particles in the valve because it would create groove that are source of crevice nuclei and leakage. Also, try to fit the diameter of your valve port with the diameter of your tubing
- **Wetting:** To avoid the crevice nuclei during the priming, it is important to prime your system with a low flow velocity. It also helps if you are using a solution with a lower surface tension such as ethanol or SDS for the wetting of your system

### 4.2.3 Remove the trapped bubbles

To remove the bubbles trapped in your system, you can tap on the tubing or induce vibration to your system. The most efficient way we have found is to flow a large gas (air) bubble followed by a solution containing ethanol: the air train picks up all the trapped bubbles and the ethanol brings a good wetting on the surfaces.

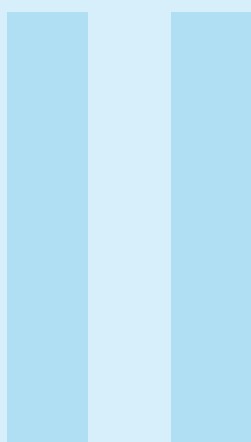

# Software

<b>5</b>	<b>Software Communication</b> .....	<b>24</b>
5.1	Communication Protocol	
<b>6</b>	<b>Coding examples</b> .....	<b>33</b>
6.1	Labview VI	
6.2	Python scripting	

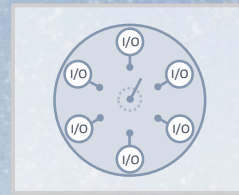

## 5. Software Communication



### 5.1 Communication Protocol

The RVM rotary valve offers a data terminal protocol.

#### 5.1.1 Data Terminal Protocol

The data terminal protocol enables communication through the following pattern:

Character Format	
Parameter	Setting
Baud rate	9600
Data bits	8
Parity	None
Stop bit	1
Command Block	
1	Start command (ASCII “/”)
2	Valve address (1 by default)
3	Data block (length n)
...	
3+n-1	
3+n	Carriage Return (<CR>)
Answer Block	
1	Start answer (ASCII “/”)
2	Master address (ASCII “0”)
3	Error/Status character
4	Data block (length n)
...	
4+n-1	
4+n	ETX (0x03)
5+n	Carriage Return (<CR>)
6+n	Line feed (0x0A)

TABLE 5.1 – Data Terminal Protocol Format



Please note that due to the buffer size limitation, the length of the command block is limited to 512 characters. If necessary, the command string has to be split to avoid overflow. The looping functions will also help to reduce the number of required characters for a given sequence.

**Example 5.1** “/1ZR<CR>” will be sent to initialize the valve (see serial command description) In return, the valve will answer with “/0@<ETX><CR><LF>”.

### 5.1.2 Using DT Protocol with Microsoft Windows

The RVM can be controlled in the following manner:

1. Connect the valve to the PC (connect the mini-USB for the low power model, and mini-USB + power cord for the fast model)
2. Open the *Device Manager* to identify which COM port is connected.
3. Open a Terminal or Terminal emulator such as RealTerm or HTerm.
4. Establish the connection by selecting the baud rate (9600), the correct communication port (here for example COM5), 8 data bits, 1 stop bit, no parity and no flow control.

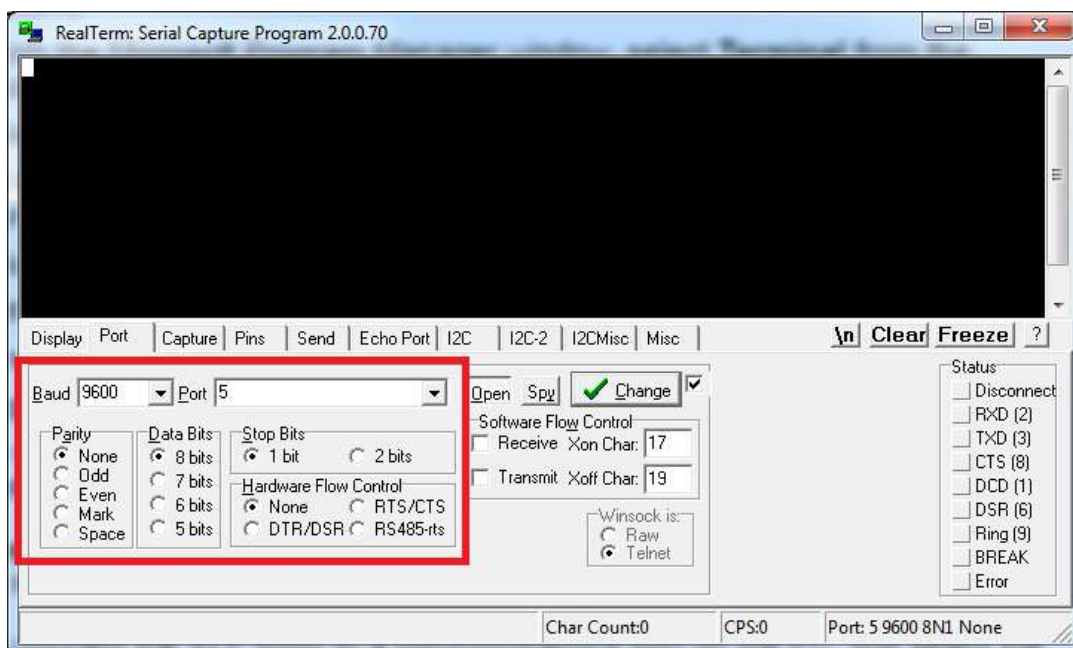

FIGURE 5.1 – Settings for serial communication

5. Press *Change* to start the connection (make sure that the *Open* button is pushed).
6. Click on the *Send* tab. Send /1ZR<CR> with the *Send ASCII* button. The *End of Line* chars can usually be added automatically (here by ticking the +CR box).

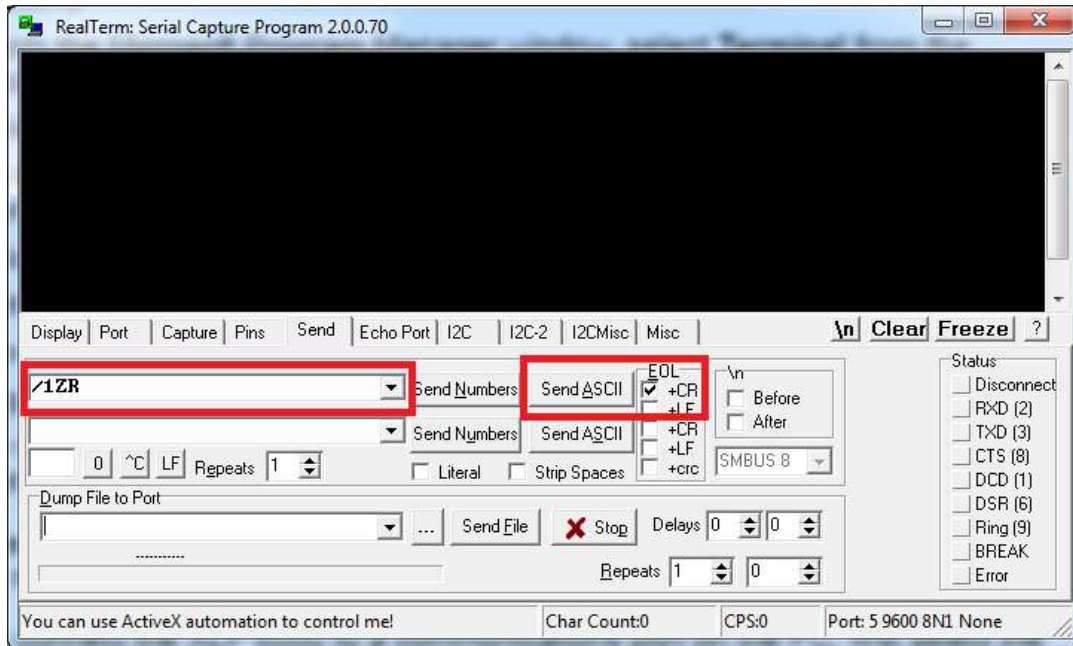

FIGURE 5.2 – Sending command configuration

7. Refer to the complete set of commands to use the rotary valve according to your need.

### 5.1.3 RVM Command Set

The RVM simplifies your microfluidic automation thanks to a wide and well-tried command set.



*This document describes the command set for the version 0.3.67 of the RVMFS firmware and for the version 0.3.16 of the RVMLP firmware. Some functionalities may not be supported with older versions. If the valve returns an error when a correct command is sent, it is likely that the firmware needs to be updated. The latest version of the firmware can be downloaded on our website at the following address: <https://amf.ch/resources/>.*

#### Command Execution Guidelines

- Most commands must be followed by the character [R] to be run, apart from commands starting with "?" or "!" and from commands T, X, H and Q.
- During the execution of a command, no new command is accepted, except for interrupt and report commands.
- The valve answers immediately after a command was sent. If an invalid command has been sent in the command string, the valve reports an error immediately.

## Valve Configuration Commands

Command	Operand Range	Default Operand	Operand Description	Command Description
@ADDR=<n>	1..9 or A..E	1	1-character address	Valve address, "_" is broadcast address
!50<n>	0,1 or 2	0	Answer mode No trailing [R]	Synchronous mode "0" : answer once when the command has been processed / Asynchronous mode "1" : answer when the command starts, for each query and when command is completed / Asynchronous mode + command counter "2" : same as asynchronous but add number of subcommand processed in its last answer (no trailing [R]). See Example 5.2.
!80<n>	4, 6, 8, 10, 12, 16 <sup>1</sup> , 20 <sup>1</sup> or 24 <sup>1</sup>	6	Number of valve positions No trailing [R]	Valve configuration (no trailing [R]). <sup>1</sup> These configurations require the stop on middle function to be enabled to work properly
!8<n>	0 or 1	0 or 1 <sup>1</sup>	Stop on middle No trailing [R] (RVMFS only)	Function to stop the motor between 2 positions, to close the valve. "0": function disabled, this is the normal behaviour. "1": function enabled. See Example 5.3. <sup>1</sup> Disabled by default for ≤12 positions, enabled by default for >12 positions.
!17			No trailing [R]	Reset valve motion counter (no trailing [R])
-			Slow mode (RVMFS only)	Speed configuration (RVMFS only)
+			Fast mode (RVMFS only)	Speed configuration (RVMFS only)
@AUTHOM= <n>	0 or 1	0	Automatic homing (RVMFS only)	Defines the activation of automatic homing when the valve is powered on. "0": automatic homing disabled (by default). "1": valve automatically homed when powered on.
@RS232			RS232 communication mode (by default) (RVMFS only)	Activate RS232 communication or serial-over-USB communication (activated by default) and deactivate RS485 communication (RS232 communication will not work if the mini USB cable remains plugged)
@RS485T <sup>1</sup>			RS485 mode with answers terminated by <LF> (RVMFS only)	Activate RS485 communication and deactivate RS232 communication (RS485 communication will not work if the mini USB cable remains plugged) <sup>1</sup> Soldering of an additional component is required to use RS485
@RS485F <sup>1</sup>			RS485 mode without <LF> ending (RVMFS only)	Activate RS485 communication and deactivate RS232 communication (RS485 communication will not work if the mini USB cable remains plugged) <sup>1</sup> Soldering of an additional component is required to use RS485

When RS485 communication mode is activated, the module will not answer nor respond to query addressed via broadcast. But any command sent via broadcast will be performed. Hence if several modules are connected on a RS485 communication line, all the modules can be controlled with the broadcast address but no answer will be sent. In order to receive an answer from a specific module, each module has to have an unique address and it has to be addressed specifically.

When the module has RS485 communication activated, the firmware cannot be updated using the LSPoneQuick software.



*If a valve is not answering to requests sent by the broadcast command, it is likely that the module has RS485 communication activated.*

**Example 5.2** How to use answer mode:

Answer mode	Description	Example	Answer	Timing
Synchronous	Only answer once when the command has been processed, can't have embedded queries	/_P100D50R	/0@	Immediate
Asynchronous	Answer when command starts, for each query and when command has ended, can have embedded queries	/_P100?4?49D50R	/0@ /0'100 /0c /0'	Immediate + after each query + after last command
		/_P100D50R	/0@ /0'	
Asynchronous + command counter	Same as asynchronous but add number of subcommand processed in its last answer	/_P100?4?49D50R	/0@ /0'100 /0c /0'4	Immediate + after each query + after last command
		/_P100D50R	/0@ /0'2	

**Example 5.3** How to use the stop on middle functionality on a 6-port valve:

Command	Description	Answer (Synchronous mode)
/_!8012	The valve is first set in 12 positions mode. The number of ports of the regular valve configuration should be doubled (12 for a 6-port, 16 for an 8-port, etc...)	/0'12 ports mode
/_!81	Enable the stop on middle functionality, so the 6-port valve can work in a 12 positions configuration	/0'Stop on middle enabled
/_ZR	Initialize the valve. Once it is done, the valve is positioned on port 1 (opened)	/0@
/_B2R	Go to position 2: closed position between physical ports 1 and 2. (All the even positions are closed)	/0@
/_B3R	Go to position 3: corresponds to physical port 2. (All the odd positions are opened)	/0@

### Control Commands

Command	Operand Range	Default Operand	Operand Description	Command Description
R	N/A	N/A		Execute command string
X	N/A	N/A	No trailing [R]	Re-execute last executed command string
G<n>	0...60000	0	0 = Loop forever	Repeat command sequence
g	N/A	N/A	Loop depth = max 10	Mark the start of a repeat sequence
M<n>	0..86400000		Milliseconds	Delay command execution
H	N/A	N/A	No trailing [R]	Halt command - Pause the sequence after finishing the current move. The paused sequence will resume with "/1R<CR>" or alternatively the user can send a new command. The command H can also be integrated in a sequence to introduce a pause before the execution of the remaining commands
T	N/A	N/A	No trailing [R]	Hardstop - Interrupt the current move and suppress it from the sequence. The interrupted sequence will resume with "/1R<CR>" after the interrupted command or alternatively the user can send a new command

**Example 5.4** "/1gB1M1000B3M2000G3R<CR>" will trigger 3 times : move to port 1, wait 1s, move to port 3. wait 2s.  
"/1B2HB1R<CR>" will trigger a move to port 2. The module will then wait for "/1R<CR>" before executing the move to port 1. The Halt command can also be executed on the fly. ■

### Initialization Commands

Command	Operand Range	Default Operand	Operand Description	Command Description
Z	N/A	N/A		Home the valve
Y	N/A	N/A		Home the valve

### Valve commands

Command	Operand Range	Default Operand	Operand Description	Command Description
B<n>	1..12	N/A	Enforced shortest plug movement	Move to valve port with shortest path independently of the current valve position. Clockwise/incremental direction preferred
b<n>	1..12	N/A	Shortest plug movement	Move to valve port with shortest path if target port is different from current port. Clockwise/incremental direction preferred
I<n>	1..12	N/A	Enforced incremental plug movement	Move to valve port independently of the current valve position. Clockwise/incremental direction
i<n>	1..12	N/A	Incremental plug movement	Move to valve port if target port is different from current port. Clockwise/incremental direction
O<n>	1..12	N/A	Enforced decremental plug movement	Move to valve port independently of the current valve position. Counter-clockwise/decremental direction
o<n>	1..12	N/A	Decremental plug movement	Move to valve port if target port is different from current port. Counter-clockwise/decremental direction

### Report Commands

These commands do not need a trailing [R] character.

Command	Description
Q	Current status
?6	Report valve position
?17	Report number of valve movements
?18 or %	Report number of valve movements (since last report)
?19	Report speed mode the valve (RVMFS only)
?20 or #	Report firmware checksum
?23 or &	Report firmware version
?26	Report valve address
?29	Same as Q (query, status and error bytes)
?76	Report valve configuration
?80	Report activation state of the stop on middle feature
?500	Report answer mode
?801	Number of valve positions
\$	Internal reset
*	Report supply voltage (x0.1 V)
?9000	Unique ID
?9200	Detailed status of the valve
@AUTHOMR	Report activation state of the automatic homing

### Error codes

The RVM immediately sends a response every time an instruction is sent to it. Error 10 and in some cases error 8 cannot be found with this immediate response. The user must send the command Q to get the status in that case.

Bit	7	6	5	4	3	2	1	0
Value	0	1	Status Bit	0	Error Code			

TABLE 5.2 – Detail of the error byte as returned after a query “/1Q”

Status Bit 5	Description
X=0	The valve will only accept report commands
X=1	The valve is ready to accept new instructions

TABLE 5.3 – Status bit description

Error Byte 7 6 5 4 3 2 1 0	Symbol ASCII		Error	
	if Bit 5 = 0	if Bit 5 =1	Code	Description
0 1 X 0 0 0 0 0	@	'	0	No Error
0 1 X 0 0 0 0 1	A	a	1	Initialization
0 1 X 0 0 0 1 0	B	b	2	Invalid command
0 1 X 0 0 0 1 1	C	c	3	Invalid operand
0 1 X 0 0 1 0 0	D	d	4	Missing trailing [R]
0 1 X 0 0 1 1 1	G	g	7	Device not initialized
0 1 X 0 1 0 0 0	H	h	8	Internal failure (valve)
0 1 X 0 1 0 1 0	J	j	10	Valve overload
0 1 X 0 1 1 1 0	N	n	14	A/D converter failure
0 1 X 0 1 1 1 1	O	o	15	Command overflow

TABLE 5.4 – Error codes

Status code	Name	Description
0xFF = 255	Busy	Valve currently executing an instruction
0x00 = 0	Done	Valve available for next instruction
0x90 = 144	Not homed	You forgot the homing! Otherwise, check that you have the right port configuration and try again.
E0 = 224	Blocked	Something prevented the valve to move.
E1 = 225	Sensor error	Unable to read position sensor. This probably means that the cable is disconnected.
E2 = 226	Missing main reference	Unable to find the valve's main reference magnet during homing. This can mean that a reference magnet of the valve is bad/missing or that the motor is blocked during homing. Please also check motor cables and crimp.
E3 = 227	Missing reference	Unable to find a valve's reference magnet during homing. Please check that you have the correct valve number configuration with command "/1?801". If not, change it according to the valve you are working with. This can also mean that a reference magnet of the valve is bad/missing or that the motor is blocked during homing.
E4 = 228	Bad reference polarity	One of the magnets of the reference valve has a bad polarity. Please check that you have the correct valve number configuration with command "/1?801". If not, change it according to the valve you are working with. This can also mean that a reference magnet has been assembled in the wrong orientation in the valve.

TABLE 5.5 – Detailed status of the valve (see command ?9200)

**Always double check USB cables & connections and power cable & connections. It is very easy to lose a lot of time due to faulty connections...**

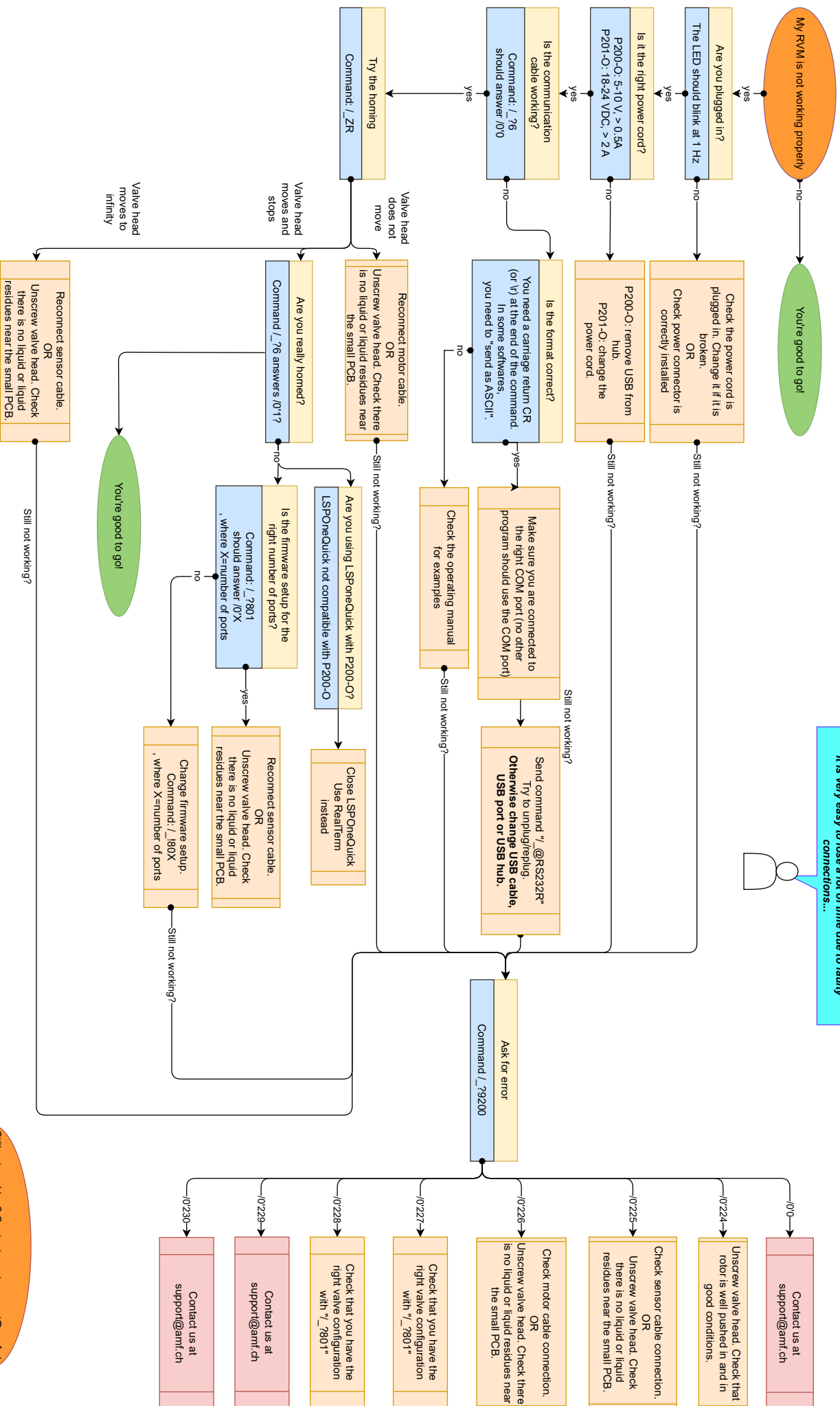



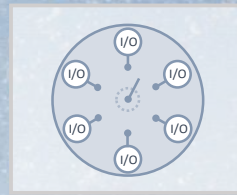

## 6. Coding examples



### 6.1 Labview VI

#### 6.1.1 Description

For ease of use, a sub-VI in Labview was created. You can directly integrate it in your current Labview setup, providing the COM port and string command as input, and observe the response from the valve to check that everything is acting as wanted.

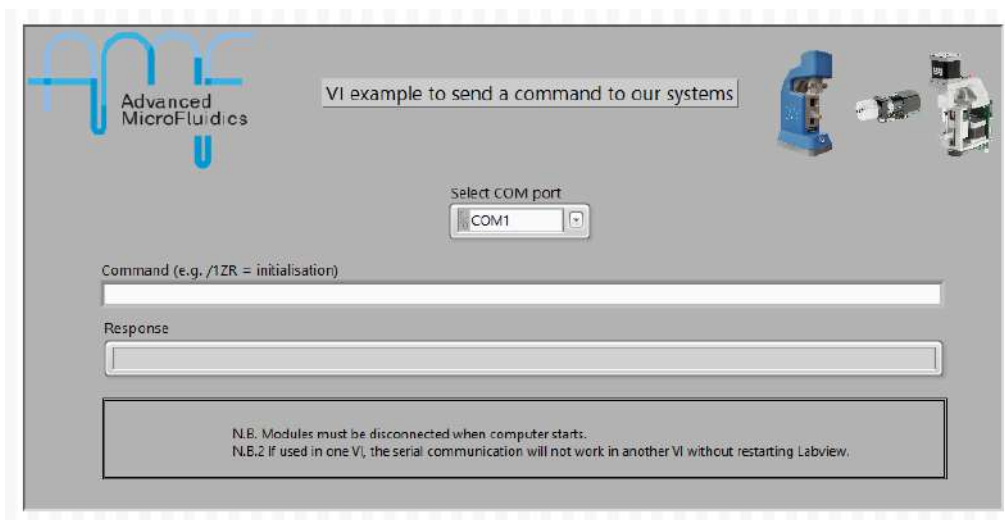

FIGURE 6.1 – Labview sub-VI, front panel - 1 apparatus

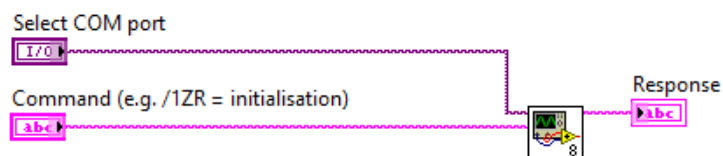

FIGURE 6.2 – Labview sub-VI, bloc diagram - 1 apparatus

It is then very simple to include several of our systems in the same setup. In the following example, the same command is sent to 2 apparatus, but it is also possible to send 2 different commands if you don't link them together.

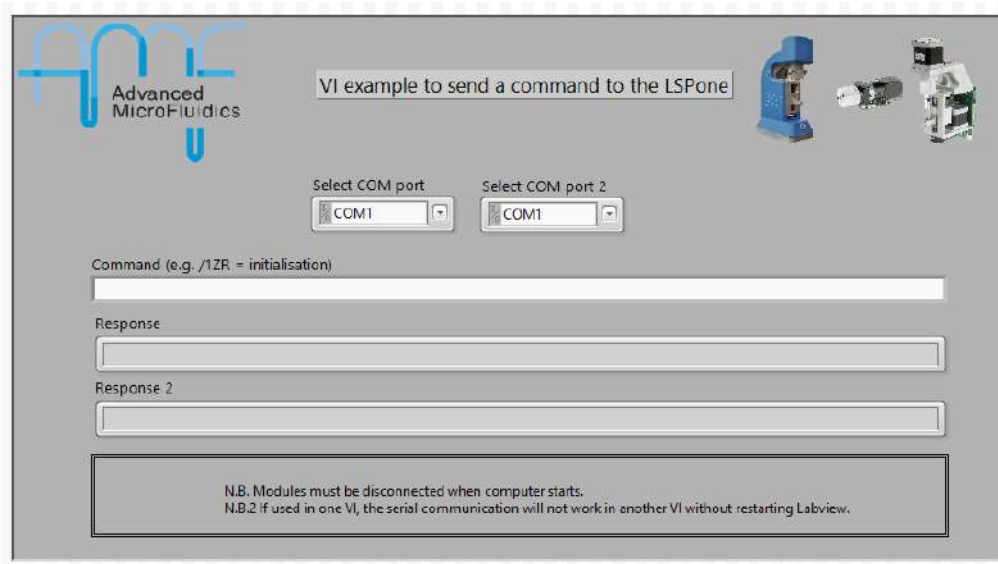

FIGURE 6.3 – Labview sub-VI, front panel - 2 apparatus (same command to both)

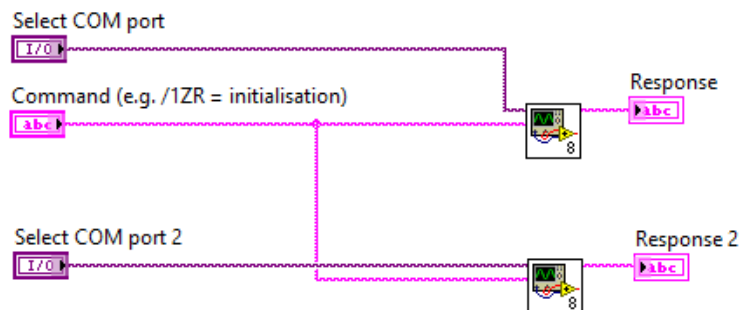

FIGURE 6.4 – Labview sub-VI, bloc diagram - 2 apparatus (same command to both)

### 6.1.2 Requirements

Nothing special is required, other than Labview from National Instruments. Tested with Labview 2016.

*N.B. In case the VI does not seem to respond, please restart Labview.*

## 6.2 Python scripting

### 6.2.1 Description

Serial commands can be sent via python scripting using the *pySerial* library. A very simple example is shown below. Python scripting will be of specific interest when using different devices and trying to automate a sequence involving these devices.

```
"""
RVM_example.py
~~~~~

This program shows how to connect to to the RVM (OEM rotary valve)
using python.
The different commands can be found in the user manual.

:copyright: (c) 2017, E. Collot
:license: Proprietary, see LICENSE for details.

"""

#include python libraries
import sys
import serial
import time

# Open serial connection -> check COM port on your device
rvm = serial.Serial('COM7', 9600, timeout=1000)
print('RVM connected on ', rvm.name)

# Initialise RVM
rvm.write(b"/1ZR\r")
time.sleep(5)
rvm.write(b"/103R\r")
time.sleep(10)
print("RVM ready")

#Here is the detail
# /1 - command start
# 03 - go to port 3, clockwise rotation
# R - command end

#Finishing the script
sys.exit(0)
```

FIGURE 6.5 – Python example script

### 6.2.2 Requirements

Python has to be installed on your computer. Additionally, the script requires the *pySerial* library (<https://pythonhosted.org/pyserial/>).