

LSPOne

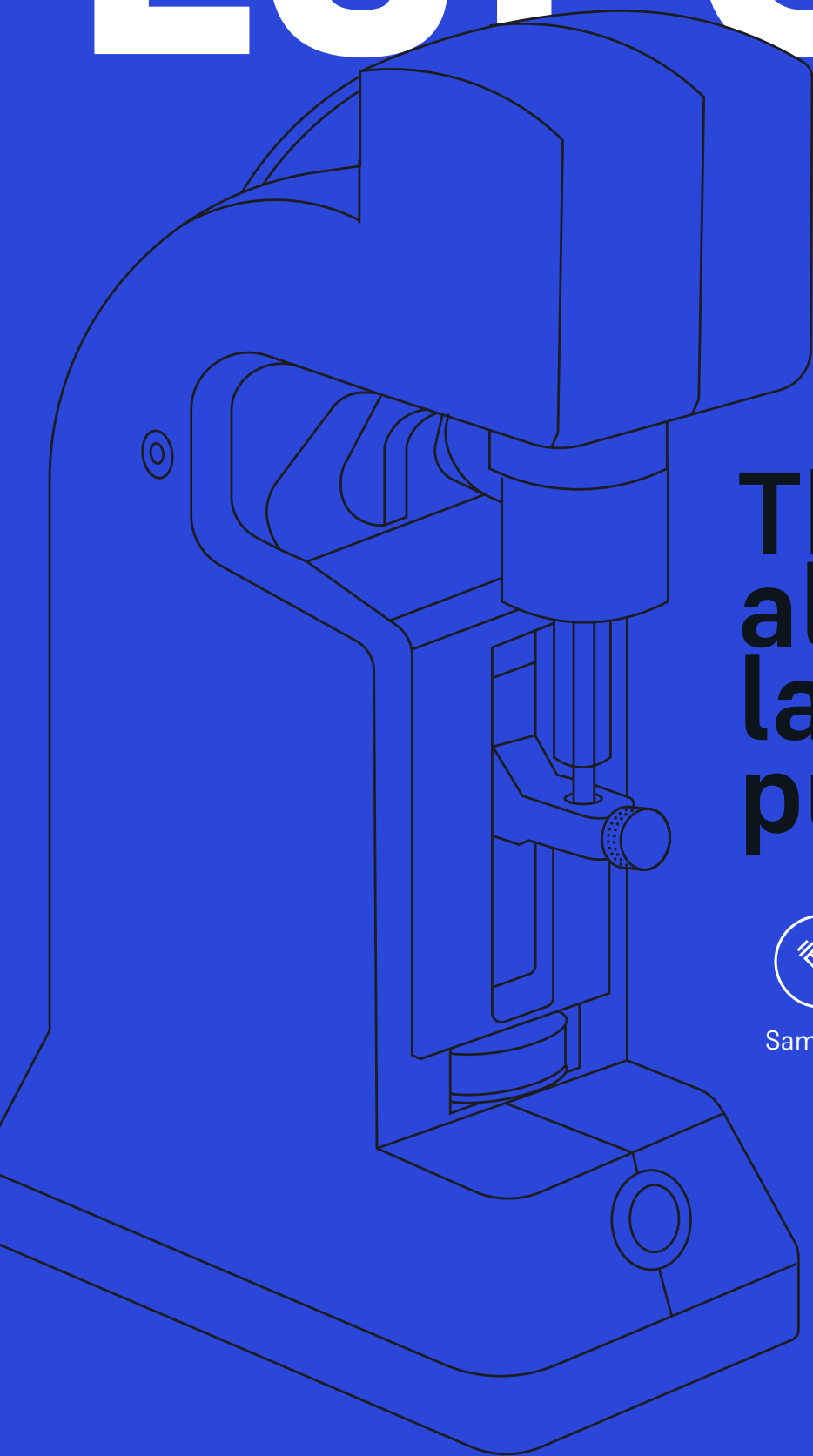

**The
all-in-one
laboratory
pump**



Sampling



Multiplexing



Automating

The LSPOne laboratory syringe pump is a high-precision dosing device for microfluidic applications. The high-accuracy dosing and nearly-pulseless flow stream capabilities make it the perfect tool for multiple liquid handling in the range of milliliter down to nanoliter.

The integrated zero dead volume selection valve allows you to handle multiple fluids with one syringe pump thanks to the high cleaning efficiency and low carryover. Coupled with its ease of use, the LSPOne is thus the ideal companion for your laboratory experiments at a reduced investment cost.



Benefits

- Plug & play, installed in minutes
- Bubble-free priming
- Small footprint
- Integrated 6-port distribution valve
- Software for Windows
- Easy custom software integration



Applications

- Lab-on-a-chip
- High-precision sampling and dosing
- Accurate flow streams of fluids
- Biological sample handling
- Industrial research
- Academic research



Functions

- Aspirate liquids
- Dispense liquids
- Control the flow rate
- Prepare complex mixes
- Dilute samples or reagents

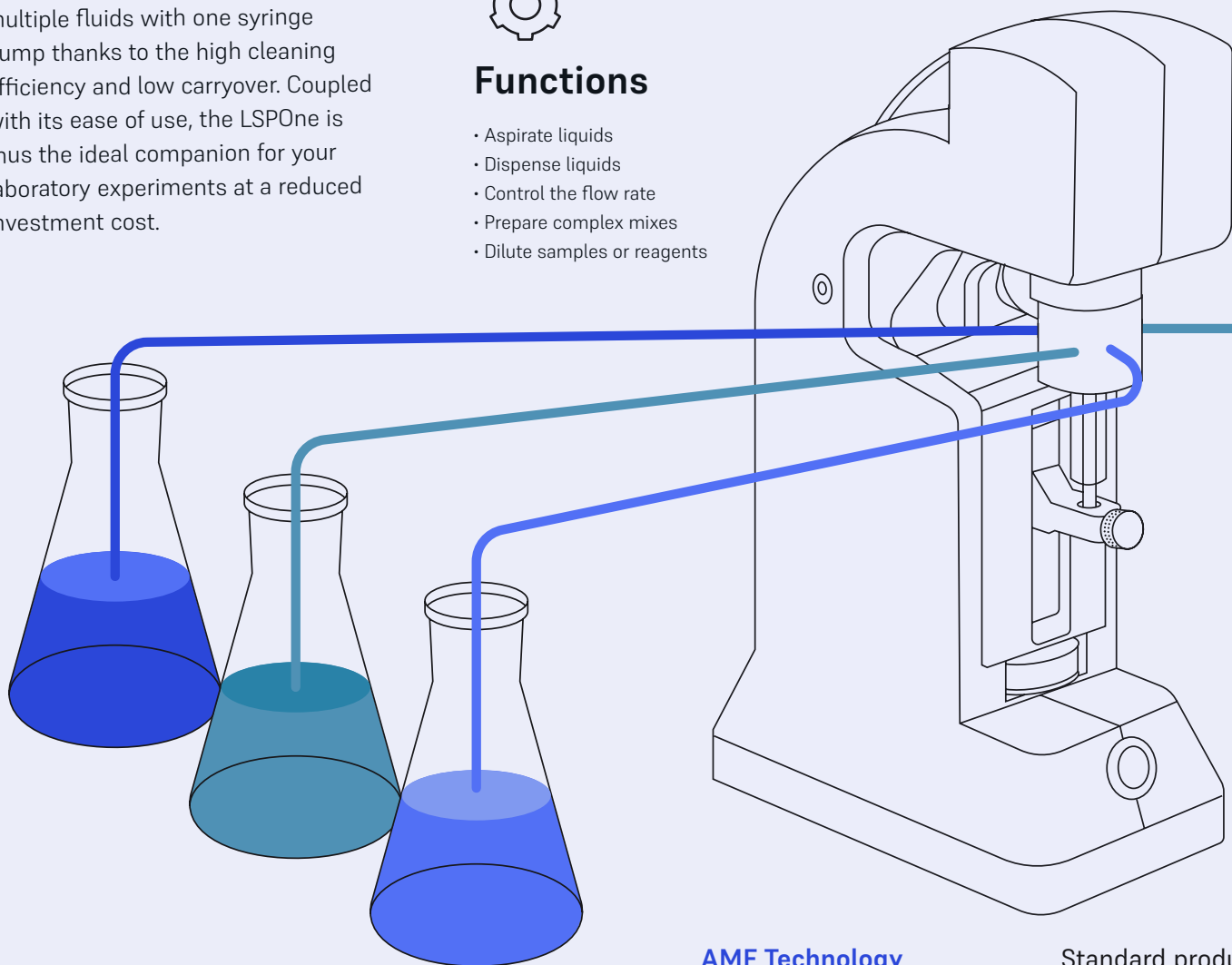



AMF Technology

Standard products

Dead, internal & carryover volumes

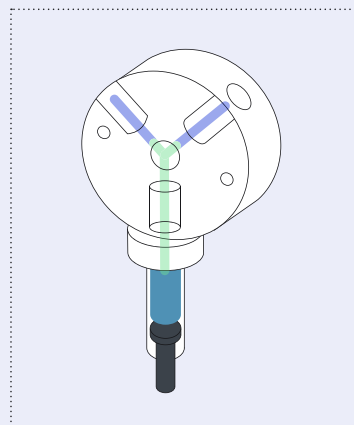
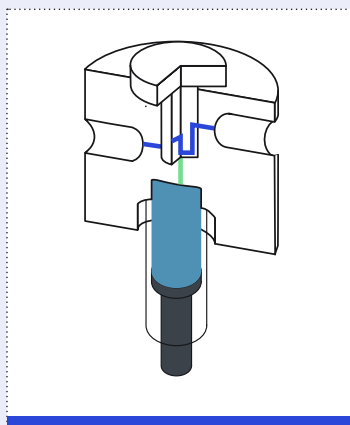
Our unique valve geometry limits the carryover volume to 1.5 μL (purple) whereas standard products exhibit up to 50 μL . The exceptionally small channel diameter of 0.5 mm reduces the internal volume to only 4 μL (blue + purple). There is no dead volume.



 Carryover volume

LSPoneQuick GUI (MS Windows)

An intuitive graphical interface was designed for easy and swift use. The macro recording allows you to create your automated sequence step-by-step and come back to it anytime.

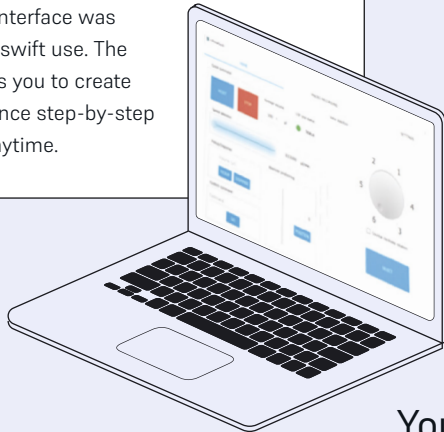

Your experiment

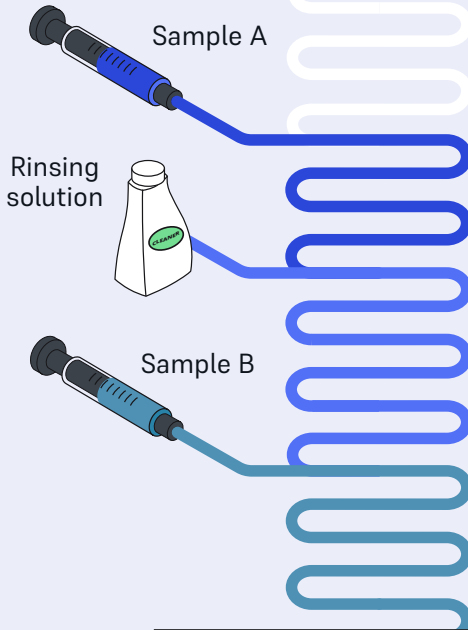

Fast liquid switching

The zero dead volume selection valve allows for a rapid liquid changeover, with an ultra-low carryover volume.

High dilution ratio

When rinsing, diluting or switching liquid, our minimal carryover volume (green) leads to a maximal dilution ratio with the diluent (blue).

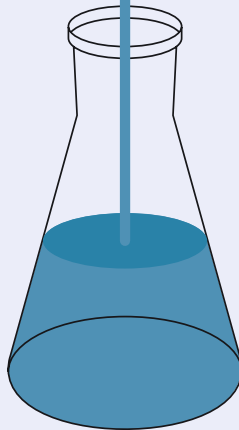

Bubble-free priming

Our distinct valve design expels the air from the syringe and valve immediately, eliminating the traditional cumbersome priming procedure.

AMF Technology

Standard products

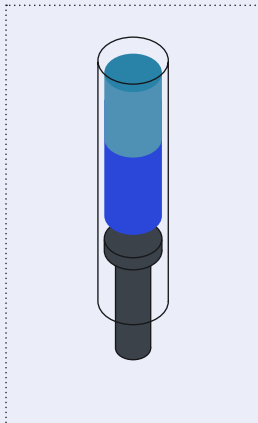
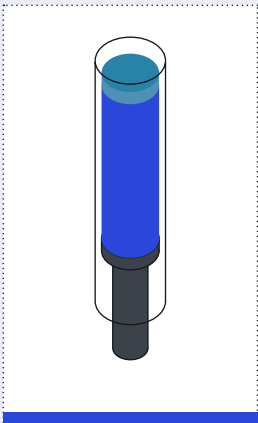

AMF Technology

Standard products

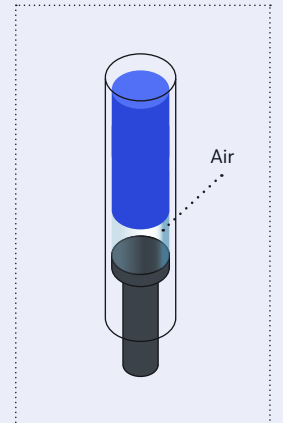
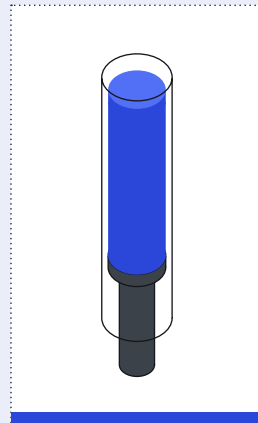

Syringe specifications

Ref.	Volume	Plunger material	Minimum flow rate	Maximum flow rate	Minimum dosing volume
S-50-P	50 µL	PTFE	0.5 µL/min	1500 µL/min	0.1 µL
S-100-P	100 µL	PCTFE	1 µL/min	3000 µL/min	0.2 µL
S-250-P	250 µL	PCTFE	2.5 µL/min	8000 µL/min	0.5 µL
S-500-P or S-500-U	500 µL	PCTFE or UHMW-PE	5 µL/min	15000 µL/min	1 µL
S-1000-P	1000 µL	PCTFE	10 µL/min	30000 µL/min	2 µL

Chemical compatibility: The wetted materials being PTFE, PCTFE and borosilicate glass, this pump offers exceptional compatibility with most chemicals and biological samples.

Valve specifications

Ref.	Configuration	Wetted materials	Internal volume	Carryover volume	Fluid path diameter	Maximum pressure
V-D-2-6-050-C-P	6 ports ultra-low carryover volume	PCTFE, PTFE	5.2 µL	1.5 µL	0.5 mm	7 bars
V-D-1-6-050-C-P	6 ports ultra-low carryover volume	PCTFE, PTFE	3.5 µL	2.6 µL	0.5 mm	7 bars
V-D-1-8-050-C-P	8 ports ultra-low carryover volume	PCTFE, PTFE	3.5 µL	2.6 µL	0.5 mm	7 bars
V-D-1-8-100-C-U	8 ports ultra-low carryover volume	PCTFE, UHMW-PE	14.1 µL	10.2 µL	1 mm	7 bars
V-D-1-10-050-C-U	10 ports ultra-low carryover volume	PCTFE, UHMW-PE	4.5 µL	2.8 µL	0.5 mm	7 bars
V-D-1-10-100-C-U	10 ports ultra-low carryover volume	PCTFE, UHMW-PE	18.1 µL	11 µL	1 mm	7 bars
V-D-1-12-050-C-U	12 ports ultra-low carryover volume	PCTFE, UHMW-PE	4.5 µL	2.8 µL	0.5 mm	7 bars

Other configurations are available upon request.

LSPone specifications

Operating temperature	15 – 40°C (59-104°F)
Operating humidity	20-80%, non condensing
Max. pressure	7 bars (102 psi)
Wetted materials	PTFE, PCTFE and borosilicate glass
Dead volume	none
Carryover volume	1.5 – 10.2 µL
Plunger travel	30 mm with 96,000 micro-steps for nearly pulseless flow
Plunger resolution	Selectable 3,000 steps (standard) / 24,000 steps (high)
Plunger drive	Screw drive with linear encoder for step loss detection
Valves configuration	Zero-dead-volume multi-port distribution with angular encoder
Tube port fittings	Standard 1/4 – 28 UNF, flat-bottom
Cross-contamination	Typically from 1/100 to 1/1000 per cleaning cycle
Accuracy	< 1% deviation from expected value at full stroke
Electrical interface	USB mini, 9-pin D-Sub (other upon request)
Interface	USB mini, RS-232, RS-485
Communication type	Serial (serial over USB, RS232, RS485)
Power	18 - 24 VDC, 2.2 A peak, 40 W / 18 VDC optimized for battery use
Time for full stroke	2 to 6000 seconds
Dimensions	245 x 143 x 85 mm
Weight	2.2 kg
Graphical user interface	MS Windows 7 and later vers.
Certifications	CE and CB certified

This table shows the technical specifications, which allow you to assess compatibility with your application.



www.amf.ch

Advanced Microfluidics SA
EPFL Innovation Park
Chemin de la Dent d'Oche 1A
CH-1024 Ecublens
Switzerland

info@amf.ch
T. +41 21 552 14 30